

72C SERIES

ASME BPE Single Stack Filter Housing

The **72C Series** single cartridge housing is designed specifically for critical filtration applications such as aseptic processing of biopharmaceutical products. It is ideal for applications where validated cleaning between batches is paramount. The hygienic, self-draining design ensures no residual product hold up for critical filtration applications such as the processing of Biopharmaceuticals, API's and Cosmetics.

Conformance to the ASME BPE standard guarantees:

- All wetted parts are manufactured in 1.4435 stainless steel with strict control of ferrite level (base metal <1%, welds <3%)
- Full traceability on materials of construction
- Designed to eliminate dead legs and ensure easy cleaning between production batches
- Full documentation pack
- ASME BPE Tri-Clamp ferrules

The **72C Series** housing will accept the full range of Amazon Single Open End industry standard cartridges ranging from 0.03 to 40µm with nominal lengths of 5, 10, 20 and 30".

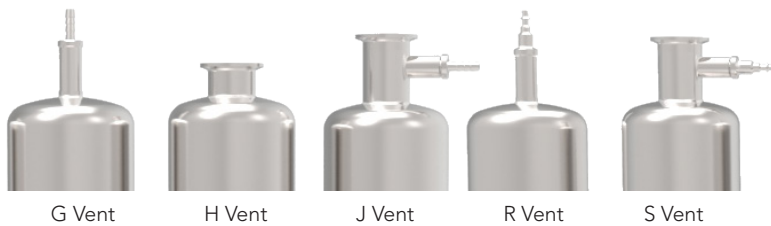

Features and Benefits

- Manufactured from 1.4435 grade stainless steel with strict control on ferrite content for improved corrosion resistance
- Hygienic design with enhanced internal geometry to aid draining and facilitate batch to batch cleaning validation
- Spring body closure clamp to simplify filter changeout
- Every housing is etched with a serial number for full material and manufacturing traceability
- Standard single open end cartridge fitting, using Bayonet code 7 for security in forward and reverse flow operation

Product Range

Amazon Filters design and manufacture an extensive range of liquid filtration systems, providing one of the widest selections of filtration vessels, depth filters and pleated cartridges available today, ensuring excellent process and filter compatibility. As one of Europe's leading manufacturers of filtration systems, Amazon Filters is able to offer a solution to meet all filtration requirements. Amazons' filters are manufactured in clean room conditions and all products come with detailed Product Validation Guides and Technical Support documentation.



AMAZON

72C Series Technical Data

Maximum Operating Conditions

Pressure Range:	Liquid:	FV / 10 bar g
	Gas Group 1:	FV / 10 bar g - 5" 10" 20" FV / 7 bar g - 30"
Temperature Range:	Gas Group 2:	FV / 10 bar g
		-10°C / 150°C

Materials of Construction

Body and Closure:	1.4435 St. Steel (wetted parts)
Clamp:	304 St. Steel

Finish

Vessel:	Mechanically polished with Electropolish to SF4 (0.38Ra) internal and SF6 (0.64Ra) external. All internal welds fully ground.
---------	---

Connections

Inlet / Outlet:	1" ASME BPE Tri-Clamp ferrules
-----------------	--------------------------------

Model	Dimensions (mm)					Volume (Litres)	Dry Weight (Kg)
	A	B	C	D	E		
72C107AG10L1USRA	386	95	-	196	250	1.6	4.2
72C117AG10L1USRA	505	93	-	196	350	2.6	4.8
72C127AG10L1USRA	760	93	-	196	600	4.5	6.4
72C137AG10L1USRA	1015	93	-	196	600	6.4	7.36

PED*/PESR Status:** Compliant with PED 2014/68/EU and PESR 2016 No. 1105

* Pressure Equipment Directive

** Pressure Equipment (Safety) Regulations No. 1105

Fluid Groups:	Gas Group 1 + 2 Liquids Group 1 + 2
Marking:	CE + UKCA

ATEX: Compliant with 2014/34/EU and Explosive Atmosphere Regulations 2016
II 2G Ex h IIB T150 Gb
II 2D Ex h IIIB T150 Db

Technical drawings for each individual housing showing dimensions, volume, weights, maximum temperatures and design pressures available on request.

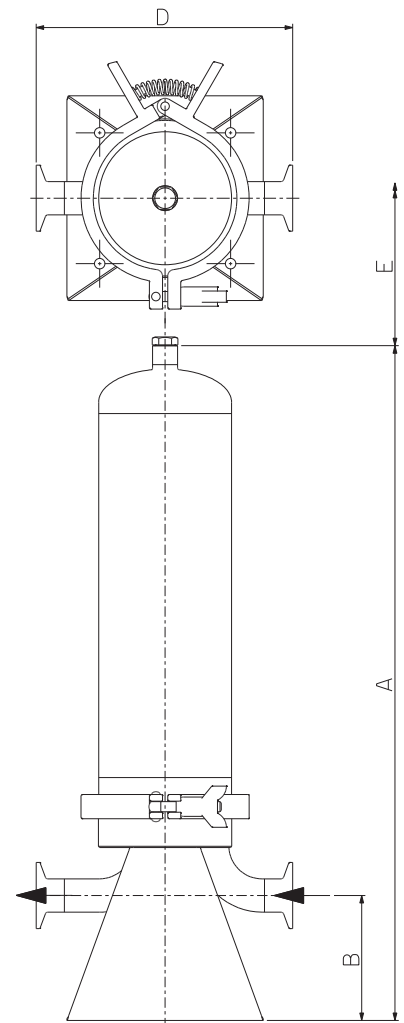

Ordering Guide

72C1	1	7	A	G	10	L	1	U	S	RA
No of Stacks	Cartridge Length	Cartridge End Cap Style	Closure Style	Vent Options	Connection	Connection Type	Materials	Finish	Seal	
1	0 - Single 5" 1 - Single 10" 2 - Double 20" 3 - Triple 30"	7 - Code 7	A - Cast Vee Clamp with Spring ¹	G - ¼" Hygienic Vent Valve H - 1½" TC Vent Only, No Clamp / Blank J - 1½" TC with ¼" Hygienic Vent Valve, No Clamp / Blank R - ¼" Hygienic Vent Valve Assembly with PTFE Seal and Staubli RBE.03.6025 S - 1½" T / C with ¼" Hygienic Vent Valve assembly with PTFE Seal and Staubli RBE.03.6025, No Clamp / blank	10 - 1"	L - ASME BPE Tri Clamp Ferrules	1 - 1.4435 St. Steel	U - SF4 Internal SF6 External	E - Ethylene Propylene K - FFKM (Kalrez equivalent) H - Gylon ² S - Silicone V - Viton	

Example: 72C117AG10L1USRA = 72C Series, 1 x 10" Code 7 cartridge, cast vee clamp with spring, ¼" Hygienic vent, 1" Tri Clamp connections. 1.4435 St Steel with SF4 internal and SF6 external electropolish.
¹ = Clamp for Gylon seal will have nut and bolt closure, not spring
² = A Style vee clamp closure only

AMAZON FILTERS LTD.

Albany Park Estate, Camberley, Surrey, GU16 7PG, ENGLAND

Tel: +44 (0) 1276 670 600 Email: sales@amazonfilters.co.uk Web: www.amazonfilters.com