

77 SERIES

Beverage Grade Multi-Stack Housing

The **77 Series** has been specifically developed for Beverage applications to provide a cost effective combination of excellent hygienic design and surface finish. It is available in 3, 5 and 8 round configurations to accommodate cartridges up to 30" long.

This leg mounted, free standing housing with domed cover is the ideal choice for all hygienic systems when using Single Open End plug in style cartridges. The simple lightweight dome allows full and easy access to the cartridges for rapid changeouts and the housings can be dismantled for full cleandowns. Bolted closures are an option available for all models.

The **77 Series** housing will accept the full range of Amazon Single Open End Code 7 industry standard cartridges ranging from 0.03 to 40µm with nominal lengths of 10, 20 and 30".

Product Features

- 'T' style construction with a high specification 0.8Ra mechanical polish inside and out
- Quick release Vee clamp closure for ease of access
- Designed to allow complete strip down for ease of cleaning.
- No loose internals for trouble free operation
- 4 different vent options
- PED and ATEX compliant
- CE marked

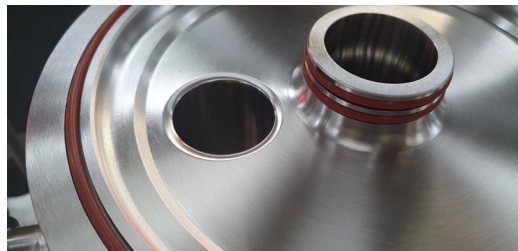

Vent Options



Drain Options

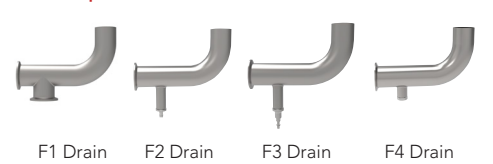

Features and Benefits

- Standard single open end cartridge fitting, using Bayonet lock code 7 for forward and reverse flow
- 316L construction for maximum corrosion resistance.
- Every housing is etched with a serial number for full traceability.
- Wide range of options available for connection size and style, cartridge lengths and materials of construction
- Full certification available, PED and ATEX compliant, CE Marked

Product Range

Amazon Filters design and manufacture an extensive range of liquid filtration systems, providing one of the widest selections of filtration vessels, depth filters and pleated cartridges available today, ensuring excellent process and filter compatibility. As one of Europe's leading manufacturers of filtration systems, Amazon Filters is able to offer a solution to meet all filtration requirements. Amazons' filters are manufactured in clean room conditions and all products come with detailed Product Validation Guides and Technical Support documentation.



AMAZON

77 Series Technical Data

Maximum Operating Conditions

	7703	7705	7708
Liquid Pressure (barg):	FV / 10	FV / 10	FV / 10
Gas Pressure (barg):	FV / 7	FV / 6	FV / 6
Temperature Range:	-10°C / 150°C		

Materials of Construction

Body and Closure:	316L St. Steel
Clamp:	304 St. Steel

Finish

Vessel:	0.8µm Ra mechanically polished inside and out with final chemical clean
---------	---

Connections

Inlet / Outlet:	7703 - 1½" Tri Clamp
	7705 - 2" Tri Clamp
	7708 - 2½" Tri Clamp

PED*/PESR**

Compliant with PED 2014/68/EU and PESR 2016 No. 1105

* Pressure Equipment Directive

** Pressure Equipment (Safety) Regulations No. 1105

Fluid Groups:	Gas Group 2 Liquids Group 1 + 2
Marking:	CE
Exceptions:	Group 1 liquids - Explosive

ATEX:

Compliant with 2014/34/EU and Explosive Atmosphere Regulations 2016
II 2G Ex h IIC T150 Gb
II 2D Ex h IIIC T150 Db

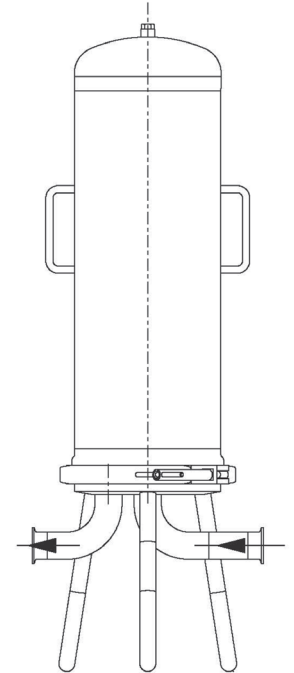
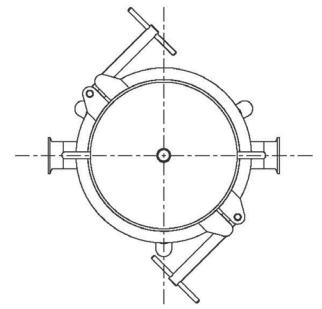

Technical drawings for each individual housing showing dimensions, volume, weights, maximum temperatures and design pressures available on request.

Ordering Guide

No of Stacks	Cartridge Length	Cartridge End Cap Style	Closure Style	Vent Options	Connection	Connection Type	Materials	Finish	Seal	Drain
7703 - 3 7705 - 5 7708 - 8	1 - Single 10" 2 - Double 20" 3 - Triple 30"	7 - Code 7	A - Cast Vee Clamp	F - ¼" BSPF Vent G - ¼" Hygienic Vent Valve H - 1½" TC Vent Only, No Clamp / Blank J - 1½" TC with ¼" Hygienic Vent Valve, No Clamp / blank	15 - 1½" (7703) 20 - 2" (7705) 25 - 2½" (7708)	L - BS4825-3 Tri Clamp M - DIN11851 N - RJTM P - SMS (Swedish) R - IDFM	1 - 316 st.st (L Grade)	T - 0.8Ra Mechanical Polish Inside & Out with Final Chemical Clean	S - Silicone V - Viton	F1 - 1½" TC Drain F2 - ¼" Hygienic Hose Barb F3 - ¼" Hygienic Staubli F4 - ¼" BSPF Drain

Example: 770517AF20L1TS = 77 Series, 5 x 10" Code 7 cartridge, cast vee clamp closure, ¼" BSPF vent, 2" Tri Clamp connections. St. Steel construction with 0.8Ra Internal and external mechanical polish

AMAZON FILTERS LTD.

Albany Park Estate, Camberley, Surrey, GU16 7PG, ENGLAND

Tel: +44 (0) 1276 670 600 Email: sales@amazonfilters.co.uk Web: www.amazonfilters.com